

# DIESEL, GAS & TURBINE ENGINES

## Meclev chock selection for diesel, gas & turbine engines

Shipyard / Customer  
 Shipname / Project  
 Classification society  
 Object  
 Make / type

## Engine

Mass  
 Power  
 Revolutions  
 Number of elements  
 Foundation bolthole diameter  
 Fitted bolthole diameter

	Kg
	kW
	rpm
	mm
	mm

## Top View of engine

Total length of engine A  
 Location first hole (seen from flex. coupling) B  
 Pitch between other holes (on one side) C  
 Total width of engine D  
 Pitch of boltholes (left to right) E  
 Foundation width (inside) F

	mm
	mm
	mm
	mm
	mm
	mm

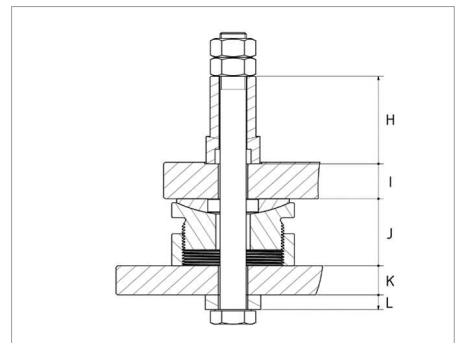
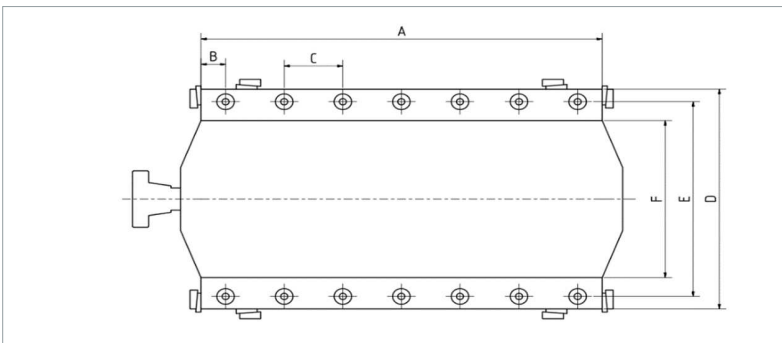

## Cross section of mounting detail

Top sleeve length H  
 Bed plate thickness I  
 Chock height J  
 Top plate thickness K  
 Bottom sleeve length L

	mm
	mm
	mm
	mm
	mm

## Remarks